

Hydrema 922 POLAR.



Reaching the most remote and isolated destinations in arctic climate or difficult terrain.

Key features

- 20 ton articulated dump truck.
- Built for arctic weather and harsh conditions.
- Three-axled and bogies with wide steering angle.
- Superior tractive power.
- Extremely low ground pressure.
- Unmatched stability.
- The market's lowest unladen weight.
- Very low fuel consumption.

Technical data and dimensions.

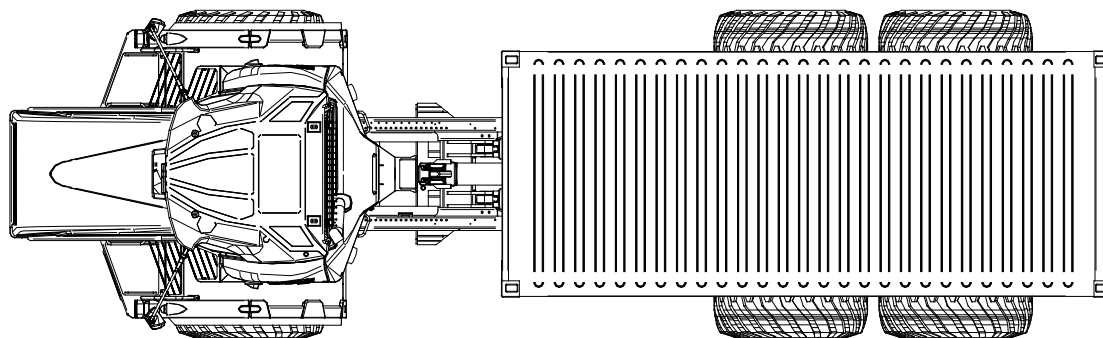
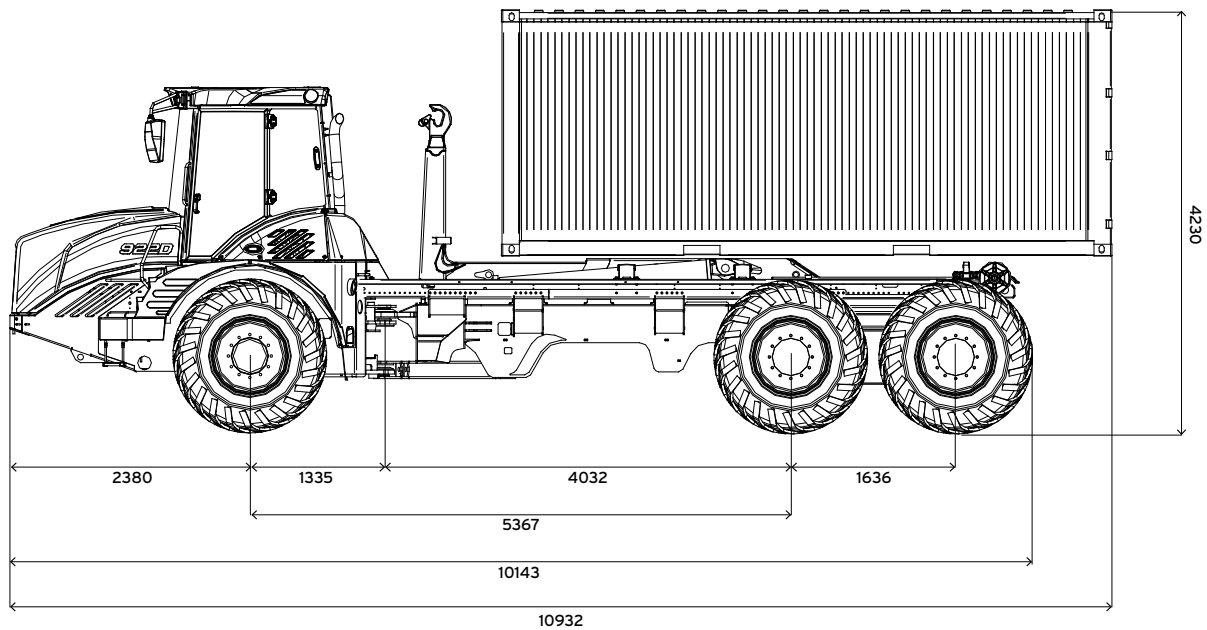

Dimensions			Technical data	
Total width	mm	3240	Engine	Cummins QSB 24 valve, 6,7 litre 6 cyl. stage 3a, with turbo and intercooler. 194 kW/264 hp at 2200 rpm.
Total height	mm	4230	Transmission	ZF ERGOWPOWER 6 WG 210 automatic transmission with 6 forward gears and 3 reverse gears.
Wheel base, bogie	mm	1636	Chassis	Articulated chassis with pendulum bar and double hydraulic stabilizers in the centre pivot. Fabricated in high tensile steel.
Wheel base	mm	5367	Axles	Front: rigid axle with electronically controlled suspension and level control. Rear: heavy-duty bogie axle with reduction gear at the differential.
Total length	mm	10932	Steering	Servo activated hydrostatic steering results in great comfort.
Overhang, front	mm	2380	Brakes	Full dual-circuit brake system with oil-immersed disc brakes on all 6 wheels. Fail-Safe parking brake.
Turning radius, outer	m	11,6	Retarder	Exhaust brake and hydraulic retarder. Automatic controlled exhaust brake.
Fuel tank	l	320	Tyres	800/45-30.5
Hydraulic tank	l	200		